

Metal detection system Vistus®

Reliable foreign object detection



German Quality



All Vistus® series detectors are manufactured using high-quality components. They have a wide frequency range for the ultimate in detection performance and reliability. Dialogues tailored to different user groups ensure optimum user friendliness. For individual requirements and applications, there are a range of variants and dimensions available.

The right solution for all of these applications:

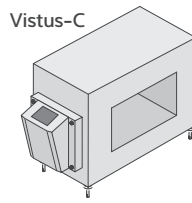
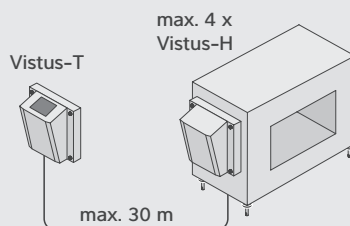
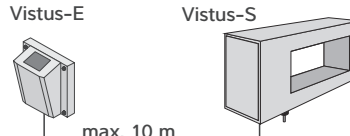
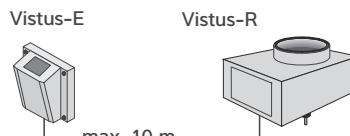
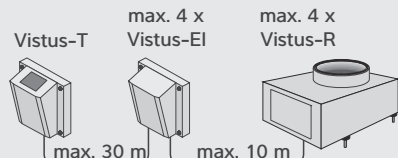

Foreign body
detection

Technical data

Possible configurations		
Equipment	Function	Diagram
Vistus-C (Compact)	Metal detector (rectangular opening) with evaluation electronics and operator terminal	 <p>Vistus-C</p>
Vistus-H (Head) Vistus-T (Terminal)	Metal detector (rectangular opening) with evaluation electronics (max. 4× in series) Separate operator terminal	 <p>Vistus-T max. 4 x Vistus-H</p> <p>max. 30 m</p>
Vistus-E (Electronic) Vistus-S (Small) Vistus-R (Round)	Separate operator terminal with evaluation electronics Metal detector (small rectangular opening) Metal detector (round opening)	 <p>Vistus-E Vistus-S</p> <p>max. 10 m</p>  <p>Vistus-E Vistus-R</p> <p>max. 10 m</p>
Vistus-T (Terminal) Vistus-EI (Electronic Interface) Vistus-S (Small) Vistus-R (Round)	Separate operator terminal Separate evaluation electronics (max. 4× in series) Metal detector (small rectangular opening) Metal detector (round opening)	 <p>Vistus-T max. 4 x Vistus-EI max. 4 x Vistus-R</p> <p>max. 30 m max. 10 m</p>  <p>Vistus-T max. 4 x Vistus-EI max. 4 x Vistus-S</p> <p>max. 30 m max. 10 m</p>

Properties and performance limits

Category	Description
Supply voltage	90 V ... 260 V
Mains frequency	47 Hz ... 63 Hz
Power consumption	28 VA (power supply up to max.100 VA)
Relay outputs	4 relays Relay 1, 3 and 4: freely programmable Relay 2 'Error': fixed assignment
Product speed	2 cm/s ... 20 m/s
Product temperature	-30 °C to +55 °C
Ambient temperature	Operation: -10 °C to +55 °C Maximum +40°C for ATEX as per directive EN 60079 (3) in potentially explosive areas in zone 22 Storage: -10 °C to +70 °C
Relative air humidity	Operation: < 58% at +55°C Storage: < 30% at +70°C
Housing	1.4301 stainless steel
Protection class	IP65 (optionally : IP69k)
Weight	See table for dimensions and weights of the relevant equipment
Maximum cable lengths between the equipment	Vistus-T to Vistus-H: 30 m Vistus-E to Vistus-R or Vistus-S: 10 m Vistus-T to Vistus-EI: 30 m Vistus-EI to Vistus-R or Vistus-S: 10 m

The properties and performance limits stated here apply for all Vistus series equipment.

Vistus-C, Vistus-H – horizontal opening

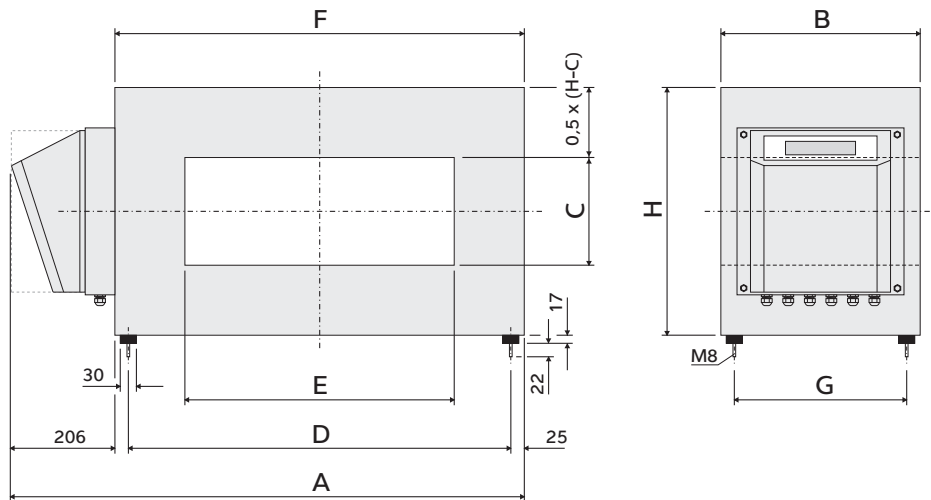

Vistus-C, Vistus-H – vertical opening

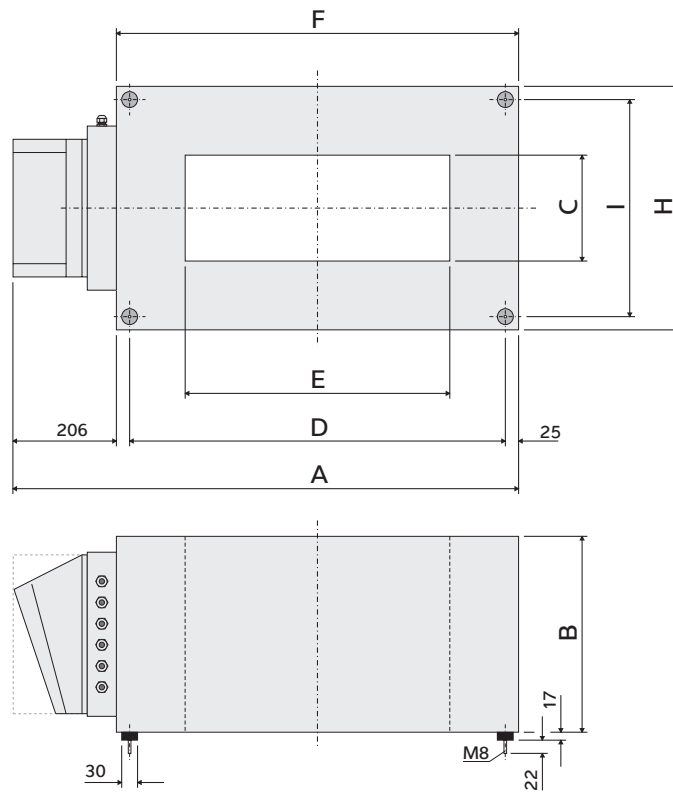

The dimensions A to I and the weight can be found in the table of all dimensions and weights.

Vistus-C, Vistus-H – upright opening

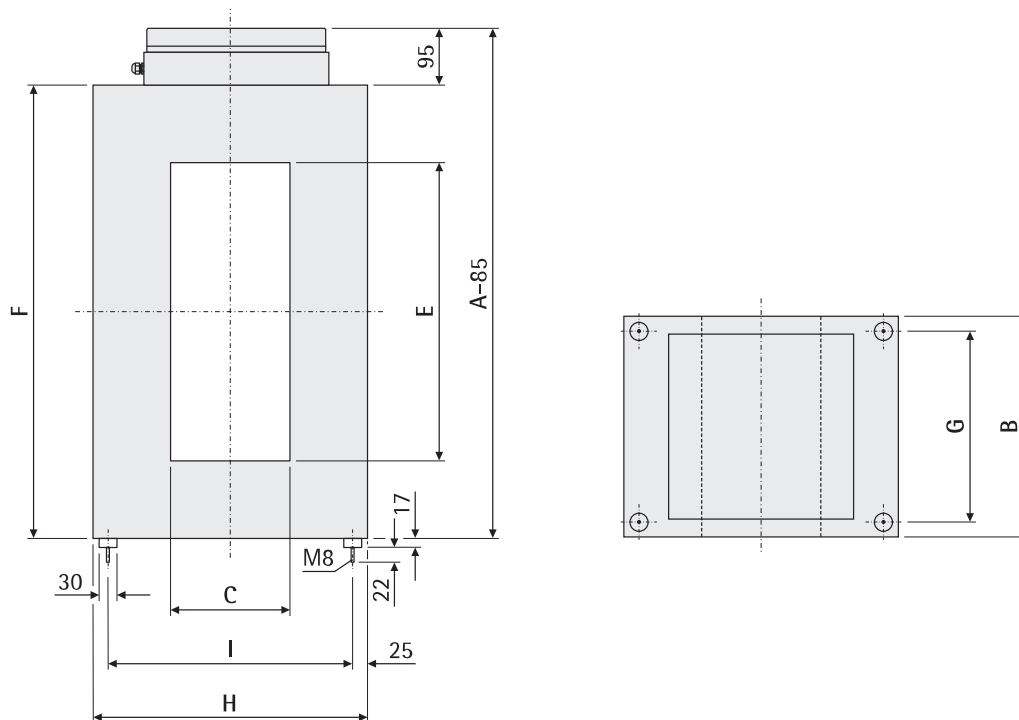

The dimensions A to I and the weight can be found in the table of all dimensions and weights.

All dimensions in mm

Vistus-C, Vistus-H – table of all dimensions and weights

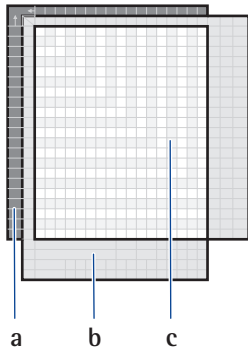

- a Product designation (e.g. Vistus-C 35 x 12.5)
- b Dimensions (A to I, see page 5) in mm
- c Weight in kg

All information excludes any possible installed optional devices, values (b and c) are approximate values.

... x ...	3	4,5	6	7,5	9	12,5	15	17,5	20	22,5	25	27,5	30	35	40	50	60	A	D	F																																												
E	30	45	60	75	90	125	150	175	200	225	250	275	300	350	400	500	600																																															
7,5	75	20	25	25	30	-	-	-	-	-	-	-	-	-	-	-	-	541	285	335																																												
12,5	125	25	30	30	35	40	40	-	-	-	-	-	-	-	-	-	-	591	335	385																																												
17,5	175	35	35	40	40	45	45	50	55	-	-	-	-	-	-	-	-	641	385	435																																												
22,5	225	35	40	45	45	45	50	55	60	65	70	-	-	-	-	-	-	691	435	485																																												
25	250	40	45	45	50	50	50	60	65	70	75	80	-	-	-	-	-	716	460	510																																												
27,5	275	45	45	50	50	50	55	60	65	70	75	80	85	-	-	-	-	741	485	535																																												
35	350	50	50	55	55	60	65	70	75	80	85	90	90	100	-	-	-	816	560	610																																												
40	400	55	55	60	60	60	65	70	75	80	85	90	95	95	105	115	-	866	610	660																																												
50	500	60	65	65	70	70	75	80	85	90	95	100	105	105	115	125	145	966	710	760																																												
60	600	70	75	75	80	80	85	90	95	100	105	110	115	115	125	135	155	1066	810	860																																												
70	700	80	85	85	90	90	95	100	100	105	110	115	120	120	130	140	160	1166	910	960																																												
80	800	90	90	95	95	95	100	105	110	115	120	125	130	130	140	150	170	1266	1010	1060																																												
90	900	95	100	100	105	105	105	110	120	125	130	135	140	140	150	160	180	1366	1110	1160																																												
115	1150	115	120	120	125	130	130	135	140	145	150	155	160	160	170	180	200	1616	1360	1410																																												
135	1350	135	140	140	145	145	150	155	160	165	170	175	180	180	190	200	220	1816	1560	1610																																												
150	1500	150	150	155	155	160	160	165	170	175	180	185	190	190	200	210	230	1966	1710	1760																																												
170	1700	165	170	170	175	175	180	185	190	195	200	205	210	210	220	230	250	2166	1910	1960																																												
195	1950	185	190	190	195	200	200	205	210	215	220	225	230	230	240	250	270	2416	2160	2210																																												
220	2200	210	215	215	220	220	225	230	235	240	245	245	250	250	260	270	290	2666	2410	2460																																												
250	2500	235	235	240	240	240	245	250	260	265	270	275	280	280	285	295	315	2966	2710	2760																																												
275	2750	255	260	260	265	265	270	275	280	285	290	295	300	300	310	320	340	3216	2960	3010																																												
B					320				370				395				420				440				460				520				580																															
G					270								320				345				370				390				410				470				530																											
H					320				335				350				385				410				435				460				485				510				535				560				610				660				760				860			
I					270				285				300				335				360				385				410				435				460				485				510				560				610				710				810			

Vistus-C, Vistus-H – metal-free zone

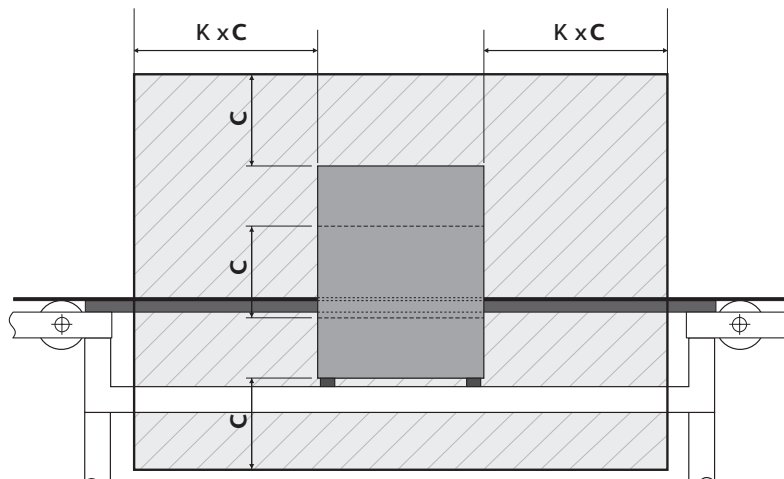

Vistus-T, Vistus-E and Vistus-EI

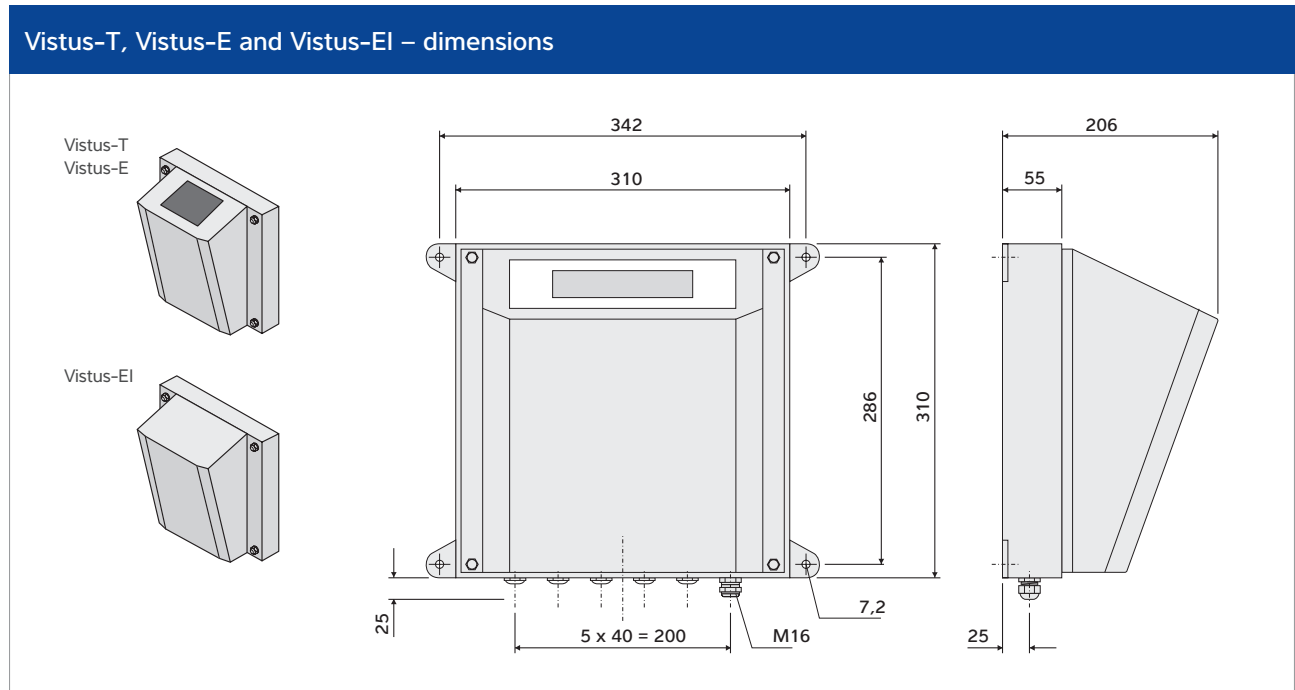

Vistus-T, Vistus-E and Vistus-EI – weight

Weight	kg
Vistus-T	Up to 6.5
Vistus-E	Up to 6.5
Vistus-EI	Up to 6.5

Vistus-R

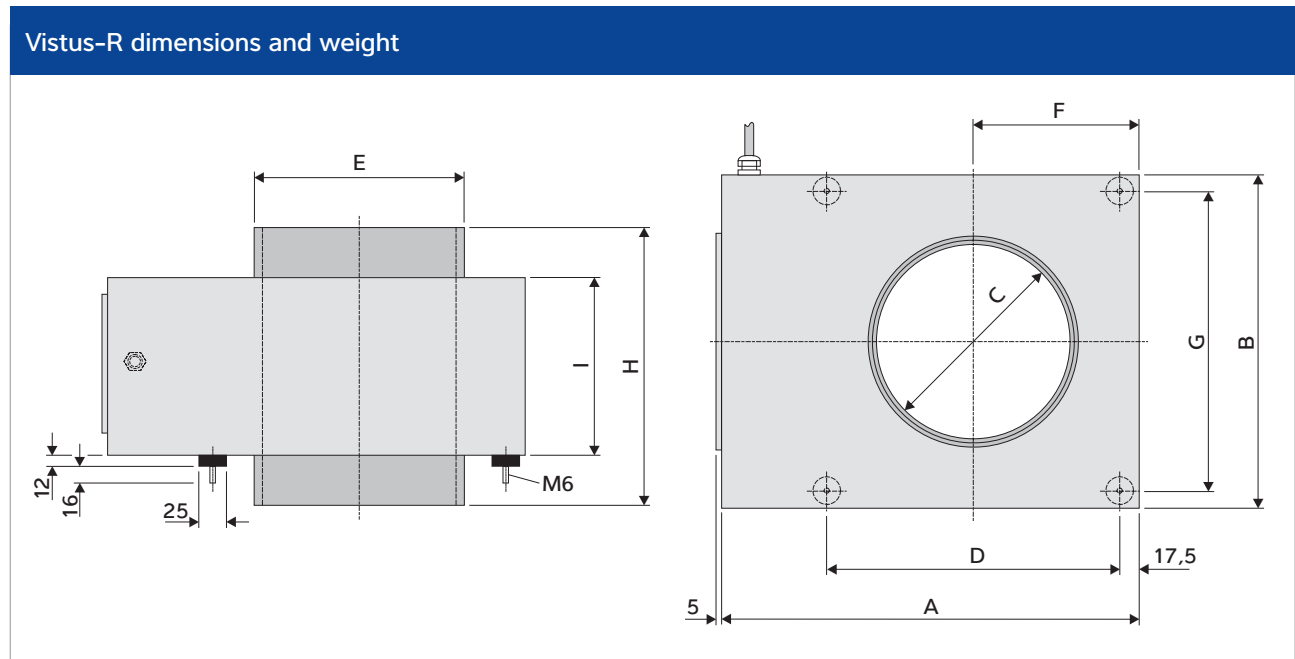

The dimensions A to I and the weight can be found in the table of all dimensions and weights.

Vistus-R – table of all dimensions and weights

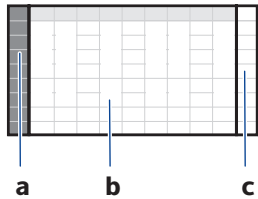

- a Product designation
(e.g. Vistus-C 35 × 12.5)
- b Dimensions
(A to I, see page 5) in mm
- c Weight in kg
- a Product designation (e.g. Vistus-R 17.2)
- b Dimensions
(A to I, see page 9) in mm
- c Weight in kg

...	A	B	C	D	E	F	G	H	I	kg
2,8			28		39,5			210		12
5,9	289	195	59	160	70,5	97,5	160	220	160	10,7
8,4			84		97,5			230		9,2
12			120		132,5			240		7,7
17,2	393	300	172	265	187,5	150	265	250	160	16,5
21,6			216		232,5			260		14,6
26,9	523	430	269	395	288	215	395	310	200	28
34,1	523	430	341	395	363	215	395	320	200	30

All information excludes any optional devices which may have been installed;
values (b and c) are approximate values.

Vistus-R– metal-free zone

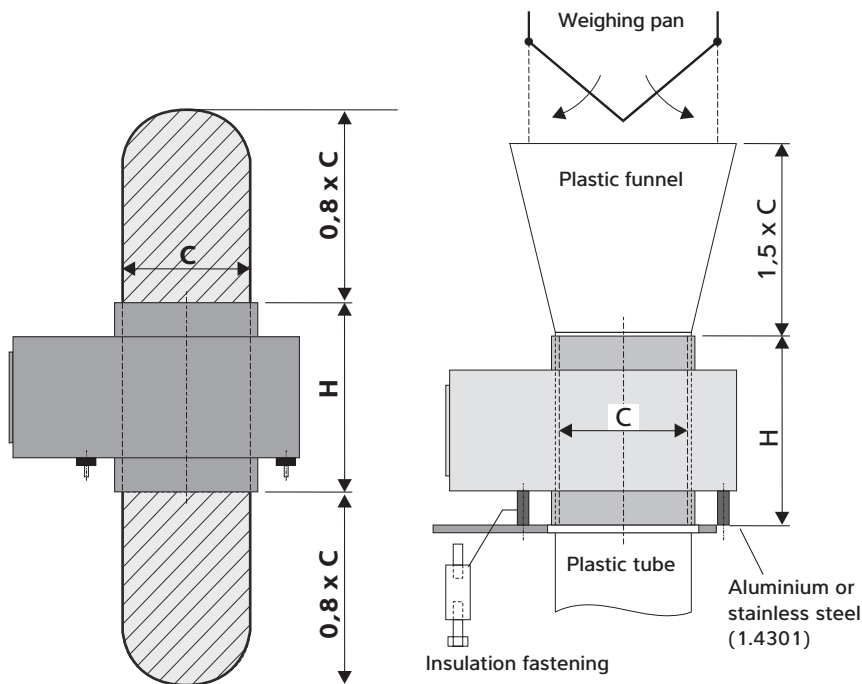

Comply with the following metal-free zone for (stainless) steel:

- both over and under the metal detector, $0,8 \times$ the opening height C

If moveable elements made of aluminium or stainless steel (VA 1.4301), such as e.g. weighing pans of a bagging machine, are operated in front of the metal detector Vistus-R then in each case a metal-free zone of $0,8 \times$ the opening height C (see page 9) must be maintained above and below the metal detector.

Vistus-R RMFZ

Vistus-R RMFZ – reduced metal-free zone

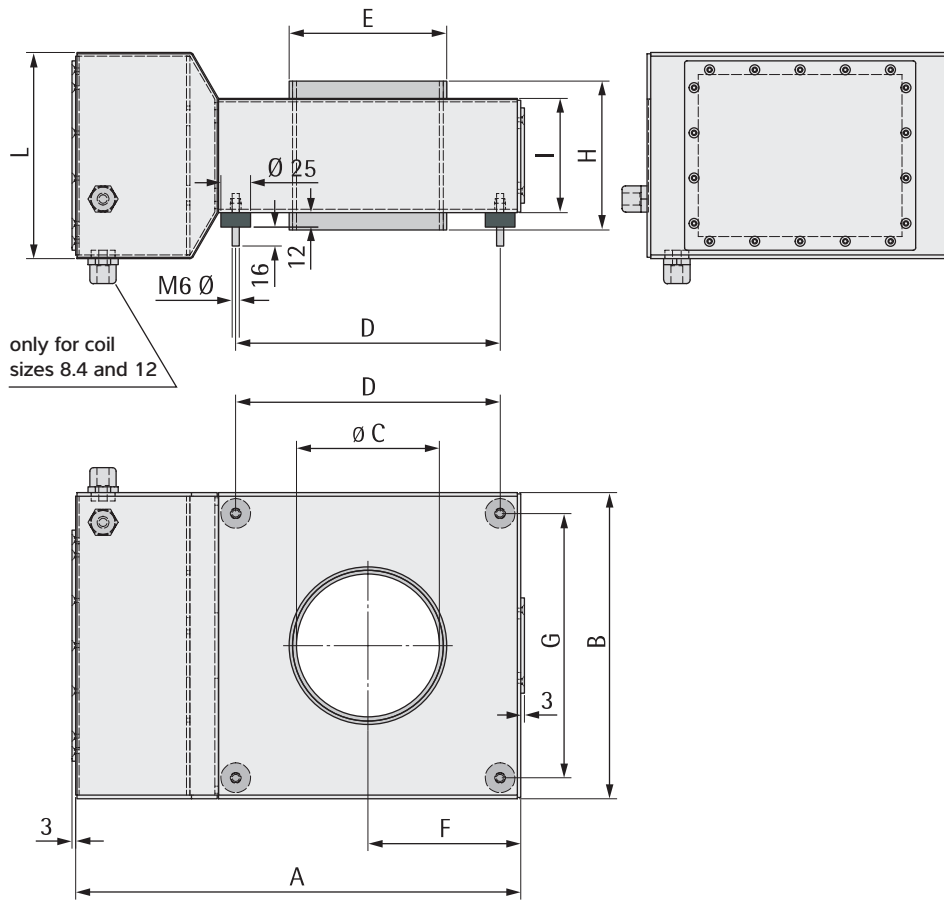

Vistus-R RMFZ – table of all dimensions and weights

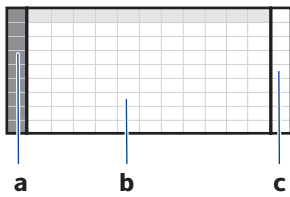

- a Product designation (e.g. Vistus-R 12)
- b Dimensions in mm
- c Weight in kg

Vistus-R...	A	B	C	D	E	F	G	H	I	J	L	kg
8,4	337	212	84	177	97,5	106	177	88	68	33	173	9,5
12	374	257	120	222	132,5	129	222	125	96	61	173	13
17,2	427	322	172	287	187,5	161	287	180	138	103	173	19,5
21,6	473	380	216	345	232,5	190	345	225	173	138	173	25
26,9	538	445	269	410	288	223	410	280	215	180	215	36
34,1	627	534	341	499	363	267	499	355	273	238	215	55

All information excludes any optional devices which may have been installed.
All dimensions and weights are approximate values.

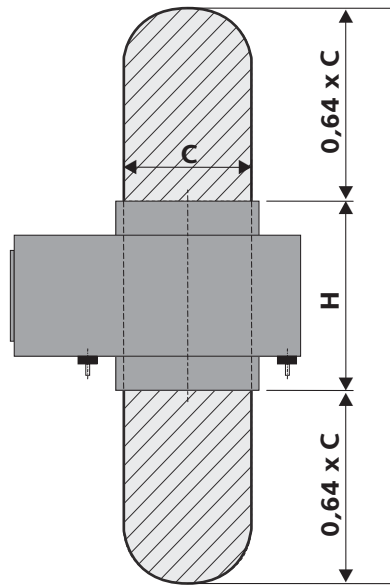

Comply with the following metal-free zone for (stainless) steel:

- in each case over and under the metal detector, $0.64 \times$ the opening height C

If moveable elements made of aluminium or stainless steel (VA 1.4301), such as e.g. weighing pans of a bagging machine, are operated in front of the metal detector Vistus-R with reduced metal-free zone then in each case a reduced metal-free zone of $0.64 \times$ the opening height C must be maintained above and below the metal detector.

Vistus-S

Vistus-S – dimensions and weight – horizontal opening

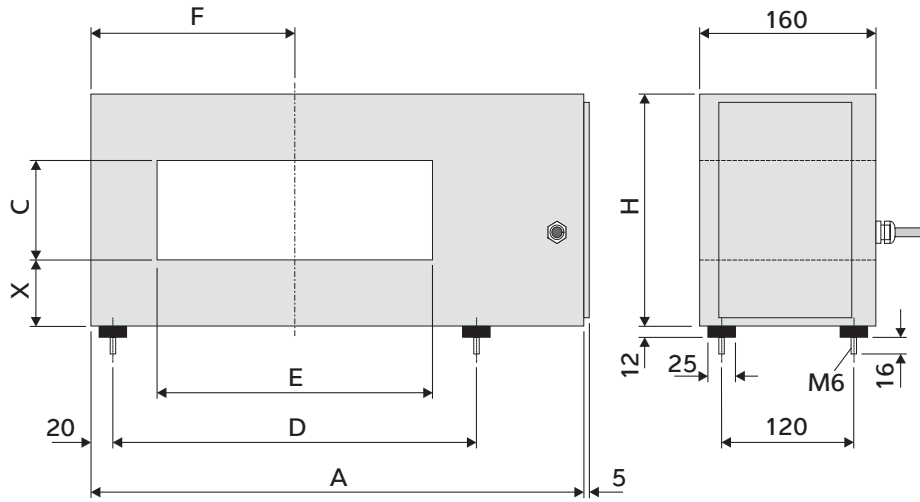

Vistus-S – dimensions and weight – vertical opening

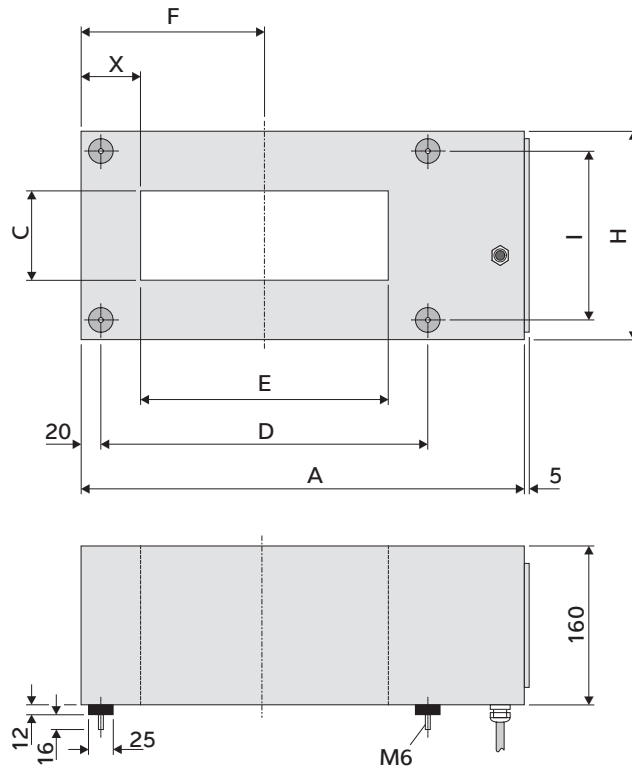

Vistus-S – upright structure

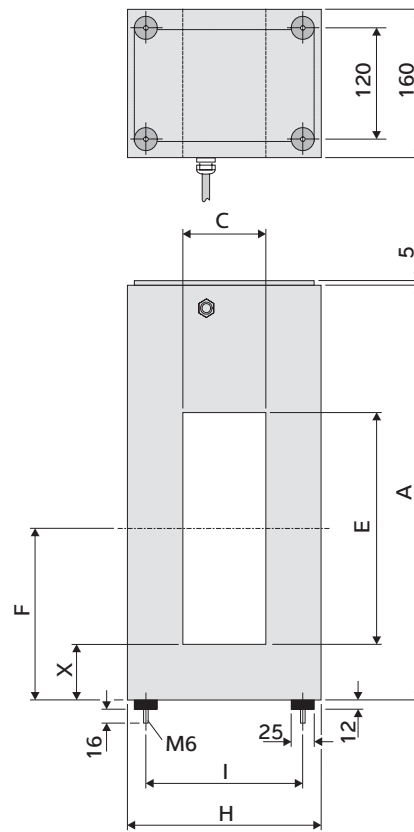

Vistus-S – table of all dimensions and weights

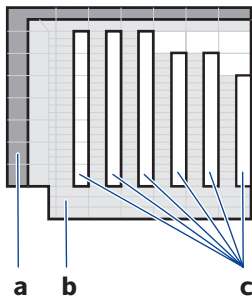

- a Product designation (e.g. Vistus-C 35 x 12.5)
- b Dimensions (A, C to F, H, I and X see page 5) in mm
- c Weight in kg

All information excludes any optional devices which may have been installed;
values (b and c) are approximate values.

... x ...		3		4,5		6		9		12,5		15	
E	C	30		45		60		90		125		150	
		7,5	75	A 333	14 kg	318	13 kg	303	12,5 kg	-	-	-	-
12,5	125	A 383	15 kg	368	14 kg	353	13,5 kg	342	14 kg	338	15 kg	-	-
		D 250		235		220		205		205			
		F 145		137,5		130		122,5		122,5			
17,5	175	A 433	15,5 kg	418	14,5 kg	403	14 kg	388	14,5 kg	388	15,5 kg	388	16,5 kg
		D 300		285		270		255		255		255	
		F 170		162,5		155		147,5		147,5		147,5	
25	250	A 508	16,5 kg	493	15,5 kg	478	15 kg	463	15,5 kg	463	16,5 kg	463	17,5 kg
		D 375		360		345		330		330		330	
		F 207,5		200		192,5		185		185		185	
35	350	A 608	18 kg	593	17 kg	578	16,5 kg	563	17 kg	563	18 kg	563	19 kg
		D 475		460		445		430		430		430	
		F 257,5		250		242,5		235		235		235	
50	500	A 758	20 kg	743	19 kg	728	18,5 kg	713	19 kg	713	20 kg	713	21 kg
		D 625		610		595		580		580		580	
		F 332,5		325		317,5		310		310		310	
60	600	A 858	22 kg	843	21,5 kg	828	19,5 kg	813	20 kg	813	21 kg	813	22 kg
		D 725		710		695		680		680		680	
		F 382,5		375		367,5		360		360		360	
H		195		195		195		210		245		270	
I		155		155		155		170		205		230	
X		82,5		75		67,5		60		60		60	

Vistus-S– metal-free zone

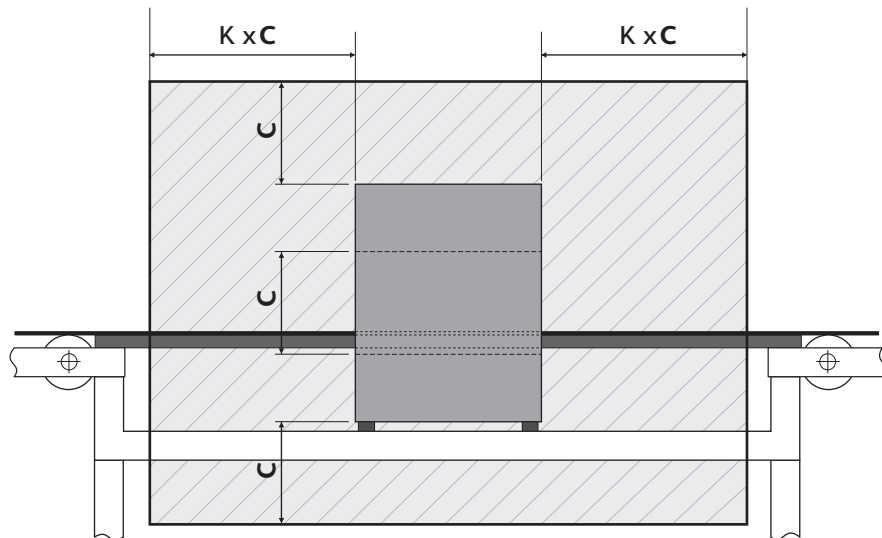

Comply with the following metal-free zone for black steel belt structures:

- in each case in front and behind the metal detector, at least a factor K of $2 \times$ opening height C
- in each case to the left and right of as well as over and under the metal detector at least $1 \times$ the opening height C

Comply with the following metal-free zone for stainless steel belt structures:

- in each case in front and behind the metal detector, at least a factor K of $1.5 \times$ opening height C
- in each case to the left and right of as well as over and under the metal detector at least $1 \times$ the opening height C

The products and solutions presented in this data sheet make major contributions in the following sectors:



Food and beverages



Pharmaceutical



Chemistry



Agribusiness

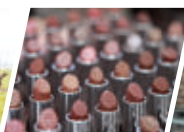

Cosmetics



Building materials



Recycling



Machinery (OEM)

The technical data given serves as a product description only and should not be understood as guaranteed properties in the legal sense.

Specifications subject to change without notice.
Rev. 02/2019

Minebea Intec Aachen GmbH & Co. KG
Am Gut Wolf 11
52070 Aachen, Germany
Phone +49.241.1827.0
sales.ac@minebea-intec.com
www.minebea-intec.com