

Tension S-type load cell PR 6246



German Quality

ⓘ PR 6246 benefits

- High measuring accuracy and repeatability
- Unrivalled reliability, robustness and stability
- Can be used in extreme operating conditions
- Quick setup

PR 6246 series load cells are specially designed for high-precision weighing of process vessels and for high-precision batching. Inverted mounting can better compensate for vessel and/or support structure movements.

For weighing process vessels and high-precision batching.

- ⓘ The series stands out thanks to its compact design, high measuring accuracy and repeatability. Furthermore, it has a high overload range of up to 150% and the highest accuracy class – up to C6.
- ⓘ Its unrivalled reliability, robustness and stability ensure years of smooth operation without the need for any readjustments.
- ⓘ The series has a particularly broad working temperature range thanks to the use of special strain-gauge technology and the hermetically sealed enclosure allows for use in extreme operating conditions and the harshest of production environments.
- ⓘ Thanks to the “matched output” technology, a damaged load cell can be replaced without the need for recalibration.

The right solution for all of these applications:



Weighing



Filling and dosing



Fill quantity control

Technical specifications

Tension S-type load cell PR 6246						
Parameters	Description	Abbr.	D1	C3	C6	Unit
Accuracy class			0.04	0.015	0.008	%E _{max}
Minimum dead load	Lowest limit of specified measuring range	E _{min}	0	0	0	%E _{max}
Maximum capacity	Highest limit of specified measuring range	E _{max}	See Ordering information table			
Safe load limit	Maximum load possible without irreversible damage	E _{lim}	150	150	150	%E _{max}
Destructive load	Danger of mechanical destruction	E _d	> 300	> 300	> 300	%E _{max}
Minimum LC verification	Minimum load cell verification interval (V _{min} = E _{max} /Y)	Y	5,000	14,000	20,000	
Deadload output return	Factor for deadload output return after load (DR=1/2*E _{max} /Z)	Z			8,000	
Rated output	Relative output at maximum capacity	C _n	2	2	2	mV/V
Tolerance on rated output	Permissible deviation from rated output	d _c	< 0.25	< 0.07	< 0.07	%C _n
Zero output signal	Load cell output signal under unloaded condition	S _{min}	0 ± 1.0	0 ± 1.0	0 ± 1.0	%C _n
Repeatability error	Max. change in load cell output for repeated loading	ε _R	< 0.01	< 0.005	< 0.005	%C _n
Creep	Max. change of output signal under E _{max} during 30 min.	d _{cr}	< 0.03	< 0.015	< 0.008	%C _n
Non-linearity	Max. deviation from best straight line through zero	d _{Lin}	< 0.03	< 0.01	< 0.01	%C _n
Hysteresis	Max. difference in LC output between loading and unloading	d _{hy}	< 0.04	< 0.015	< 0.008	%C _n
Temperature effect on S _{min}	Max. change of S _{min} in B _T	TK _{Smin}	< 0.028	< 0.01	< 0.007	%C _n /10 K
Temperature effect on parameter	Max. change of C in B _T	TK _C	< 0.03	< 0.01	< 0.005	%C _n /10 K
Input impedance	Between supply terminals	R _{LC}	650 ± 6	650 ± 6	650 ± 6	Ω
Output impedance	Between measuring terminals	R _O	610 ± 1	610 ± 0.5	610 ± 0.5	Ω
Insulation impedance	Between measuring circuit and housing at 100 V _{DC}	R _{IS}	>5,000 × 10 ⁶	>5,000 × 10 ⁶	>5,000 × 10 ⁶	Ω
Insulation voltage	Between circuit and housing (PR 6246/..E only)		500	500	500	V
Recommended supply voltage	To hold the specified performance	B _u	4 to 24	4 to 24	4 to 24	V
Max. supply voltage	Continuous operation without damage to PR 6246/..E	U _{max}	28 (EX:25)	28 (EX:25)	28 (EX:25)	V
Nominal ambient temp. range	To hold the specified performance	B _T	-10 to +55	-10 to +55	-10 to +55	°C
Usable ambient temp. range	Continuous operation without damage	B _{TU}	-40 to +95	-40 to +95	-40 to +95	°C
Storage temperature range	Without electrical and mechanical stress	B _{TI}	-40 to +95	-40 to +95	-40 to +95	°C
Vibration resistance	Resistance against oscillations (IEC 68-2-6-Fc)		20 g, 100 h, 10 to 150 Hz	20 g, 100 h, 10 to 150 Hz	20 g, 100 h, 10 to 150 Hz	–
Barometric pressure influence	Influence of barometric pressure on output	PK _{Smin}	≤ 0.005	≤ 0.0025	≤ 0.0025	%C _n /kPa
Nominal deflection	Max. elastic deformation under maximum capacity	S _{nom}	0.3	0.3	0.3	mm
Material	Load cell: 1.4542 (DIN 17 440) similar to S604, S622 (B.S.) or 17-4PH					
Protection class	IP68/IP69K					
Cable	Length: 5 m Diameter: 5 mm Cross section: 4×0.35 mm ² Cable sheath material: TPE					
Bending radius	≥ 50 mm in case of fixed installation ≥ 150 mm in case of flexible installation					

Definitions according to VDI/VDE 2637. The technical data given serves as a product description only and should not be understood as guaranteed properties in the legal sense.

NTEP classification PR 6246

NTEP			NTEP minimum LC verification interval, v_{min}							
Maximum capacity	With OIML class	Divisions n_{max}	100 kg	200 kg	300 kg	500 kg	1 t	2 t	3 t	Unit
Class III Multiple	D1	2,000	20	40	60	100	200	400	600	g
Class III Multiple	C3	5,000	--	14.3	21	36	71	143	214	g
Class III Multiple	C6	8,000	--	10	15	25	50	100	150	g
Class III L Multiple	D1	5,000	6.7	13.3	20	33	67	133	200	g
Class III L Multiple	C3	10,000	--	5	7.1	12	24	48	71	g
Class III L Multiple	C6	10,000	--	3	5	8	17	33	50	g

Technical diagrams

Tension S-type load cell PR 6246

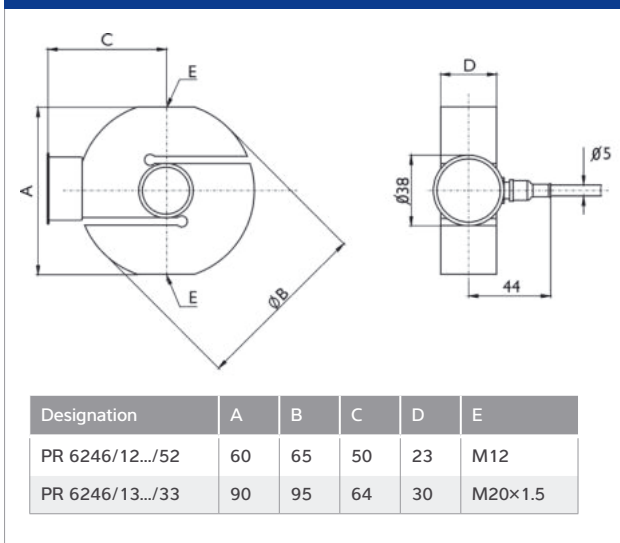

Tension S-type load cell PR 6246

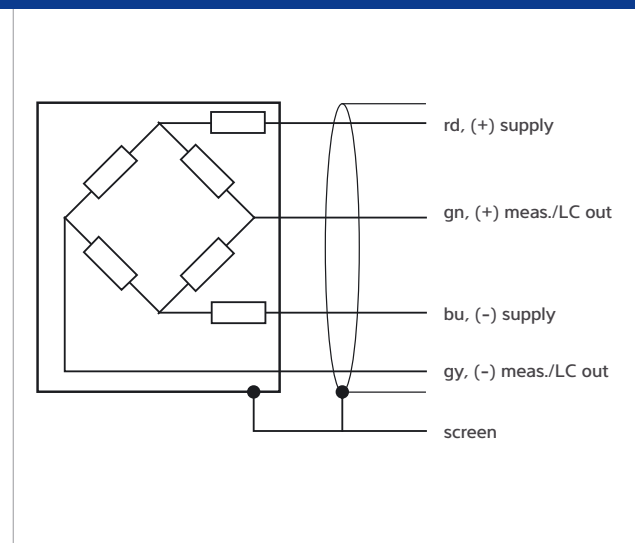

Circuit diagram

Load cell accessory – rod end PR 6046

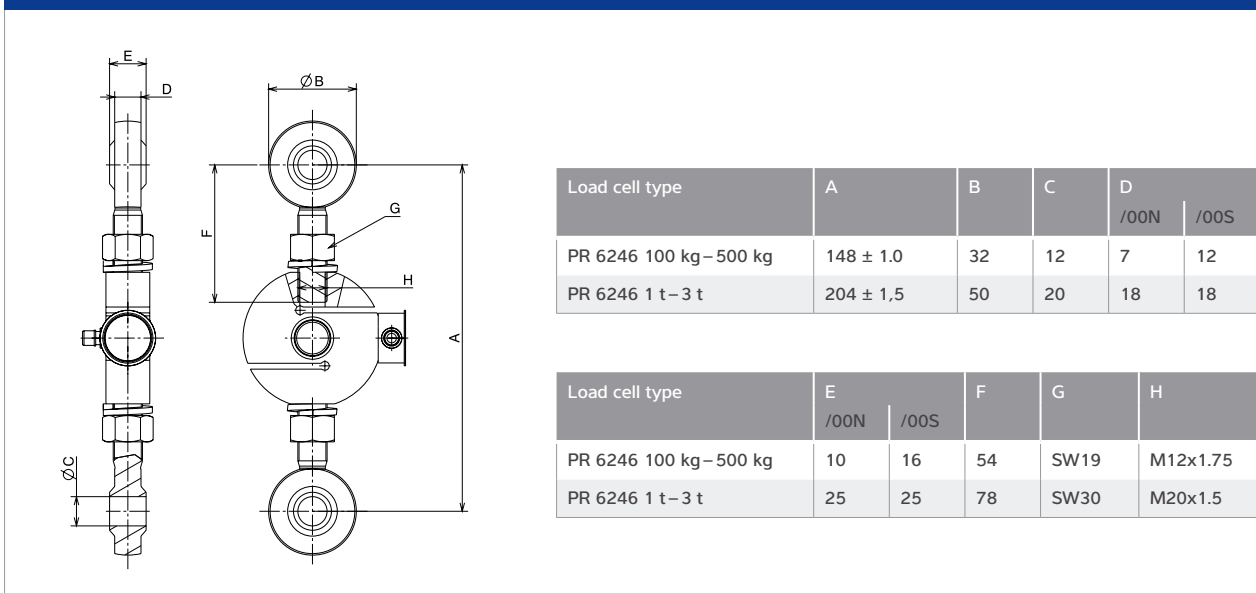

The stated values apply only for static and quasistatic applications

Ex approval

Scope of validity:

PR 6246 (100 kg to 3 t)



Explosion protection

Certificates for tension S-type load cell PR 6246

Zone	Labelling	Certificate number	For
0 and 1	II 1G Ex ia IIC T6 Ga Ex ia IIC T6 Ga	BVS 16 ATEX E 005 IECEX BVS 16.0005	PR 6246/..E only
20 and 21	II 1D Ex ta IIIC T160 °C Da Ex ta IIIC T160 °C Da	TÜV 03 ATEX 2301X IECEX TUN 17.0025X	All PR 6246 without /..E
2	II 3G Ex nA IIC T6 Gc	Manufacturer's declaration	All PR 6246 without /..E
22	II 3D Ex tc IIIC T85 °C Dc	Manufacturer's declaration	All PR 6246 without /..E
FMus	IS CL I, II, III, DIV 1, GP A, B, C, D, E, F, G Entity – 4012 101 5688 NI CL I, II, III, DIV 2, GP A, B, C, D, E, F, G NIFW – 4012 101 5688 T4A Ta = -30 °C to 70 °C; T5 Ta = -30 °C to 55 °C	FM17USO276	All PR 6246 without /..E
FMca	IS CL I, II, III, DIV 1, GP A, B, C, D, E, F, G Entity – 4012 101 5688 NI CL I, II, III, DIV 2, GP A, B, C, D, E, F, G NIFW – 4012 101 5688 T4A Ta = -30 °C to 70 °C; T5 Ta = -30 °C to 55 °C	FM17CA0138	All PR 6246 without /..E

Ordering information

Tension S-type load cell PR 6246

Type	Maximum capacity E _{max}	Version	Ex version	Packaging	Weight gross/net
PR 6246/12..	100 kg	/..D1	/..D1E	220×215×135 mm	1.2 kg/0.8 kg
PR 6246/22..	200 kg	/..D1/..C3/..C6	/..D1E/..C3E/C6E	220×215×135 mm	1.2 kg/0.8 kg
PR 6246/32..	300 kg	/..D1/..C3/..C6	/..D1E/..C3E/C6E	220×215×135 mm	1.2 kg/0.8 kg
PR 6246/52..	500 kg	/..D1/..C3/..C6	/..D1E/..C3E/C6E	220×215×135 mm	1.2 kg/0.8 kg
PR 6246/13..	1 t	/..D1/..C3/..C6	/..D1E/..C3E/C6E	220×215×135 mm	1.9 kg/1.6 kg
PR 6246/23..	2 t	/..D1/..C3/..C6	/..D1E/..C3E/C6E	220×215×135 mm	2.0 kg/1.6 kg
PR 6246/33..	3 t	/..D1/..C3/..C6	/..D1E/..C3E/C6E	220×215×135 mm	2.0 kg/1.7 kg

Load cell accessories PR 6246 – rod end sets

Type	Accessories	Description	Order number
PR 6046/00S	Stainless steel rod end mounting kit	Material – 1.4301, tension mounting kit for load cells with up to 500 kg maximum capacity	9405 360 46002
PR 6046/00N	Rod end mounting kit	Material – steel, tension mounting kit for load cells with up to 500 kg maximum capacity	9405 360 46001
PR 6046/11S	Stainless steel rod end mounting kit	Material – 1.4548, tension mounting kit for load cells with 1 t to 3 t maximum capacity	9405 360 46112
PR 6046/11N	Rod end mounting kit	Material – steel, tension mounting kit for load cells with 1 t to 3 t maximum capacity	9405 360 46111

The products and solutions presented in this data sheet make major contributions in the following sectors:



Food and beverages



Agribusiness



Building materials



Machinery (OEM)

The technical data given serves as a product description only and should not be understood as guaranteed properties in the legal sense.

Specifications subject to change without notice.
Rev. 01/2020

Minebea Intec GmbH
Meiendorfer Straße 205 A
22145 Hamburg, Germany
Phone +49.40.67960.303
sales.hh@minebea-intec.com
www.minebea-intec.com